

Project: _____

Fixture Type: _____ Quantity: _____

Customer: _____

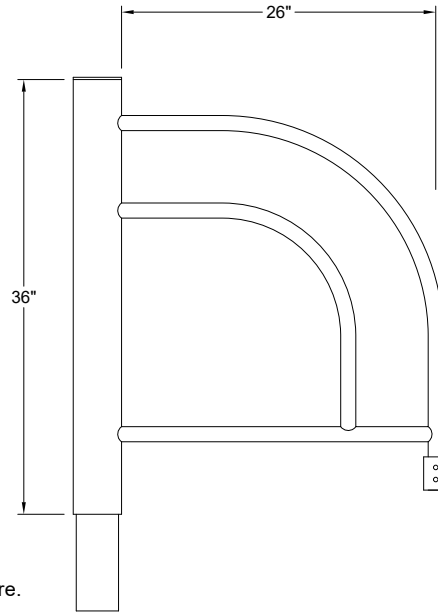

Specifications

Material:
Durable A356 cast aluminum, 6061 extruded aluminum and sheet metal. Hardware is stainless steel or zinc plated steel.

Fixture Mounting:
Dual clevis pins to tenon which aid in hang-straight, plus two locking set screws.

Post Arm Mounting:
Reverse tenon with set screws in upper portion of pole.

Minimum wall thickness for corresponding pole is 0.188" (3/16") for aluminum and 0.1793 (7ga) for steel.

Slip-over available for any pole, consult factory. Pole section of arm matches pole diameter and style (smooth or fluted).

Electrical:
Post arms are prewired with 14ga line Voltage & 18ga dimming leads.

Finish:
A polyester powder coat high quality finish. Marine grade finish is available.

Modifications:
Consult factory for custom or modified designs.

Buy American:
This product is assembled in the USA and meets the Buy America(n) government procurement requirements under FAR, DFARS, and DOT regulations. [Click here for additional information.](#)

PA041 - POST ARM

Extruded aluminum post arm for pendant luminaire.

	EPA	Weight
PA041-3-1-N-3	2.57	19.0 lbs.
PA041-3-1-N-4	2.77	20.0 lbs.
PA041-3-1-N-5	2.97	21.0 lbs.
PA041-3-1-N-6	2.17	22.0 lbs.
PA041-3-2-N-3	5.05	36.0 lbs.
PA041-3-2-N-4	5.25	37.0 lbs.
PA041-3-2-N-5	5.45	38.0 lbs.
PA041-3-2-N-6	5.65	39.0 lbs.

Catalog Logic

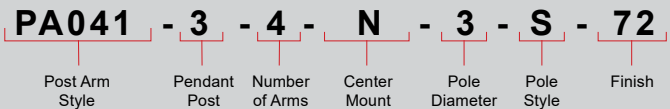

Catalog Number

PA041

1

3

2

3

N

4

5

6

1 Arm Configuration



2 Arm Configuration

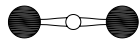

3 Arm Configuration

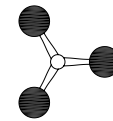

4 Arm Configuration

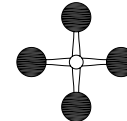

1	POST ARM ORIENTATION
3	Pendant

2	NUMBER OF ARMS
1	One Arm Configuration
2	Two Arm Configuration
3	Three Arm Configuration
4	Four Arm Configuration

3	CENTER MOUNT OPTIONS
A	Center Mount
N	No Center Mount

4	POLE DIAMETER
3	3 - 3 Inch
4	4 - 4 Inch
5	5 - 5 Inch
6	6 - 6 Inch (Smooth only)

5	POLE STYLE
S	Smooth
F	Fluted

6 FINISHES					
*Premium and Marine Grade Finish have additional charges					
Standard Colors	Standard Grade	Marine Grade*	Standard Colors	Standard Grade	Marine Grade*
Aspen Green	10	10M	Copper Clay	53	53M
Cantaloupe	11	11M	Silver	56	56M
Lilac	12	12M	Black Verde	61	61M
Putty	13	13M	Painted Chrome	70	70M
Raw Unfinished	40	NA	Painted Copper	71	71M
Black	41	41M	Textured Black	72	72M
Forest Green	42	42M	Matte Black	73	73M
Bright Red	43	43M	Textured Architectural Bronze	76	76M
White	44	44M	Textured White	77	77M
Bright Blue	45	45M	Textured Silver	78	78M
Sunny Yellow	46	46M	PREMIUM FINISH	Premium Grade*	Marine Grade*
Aqua Green	47	47M	Textured Desert	80	80M
Galvanized	49	NA	Graystone	82	82M
Navy	50	50M	Oil Rubbed Bronze	83	83M
Architectural Bronze	51	51M	Carbon Graphite	96	96M
Patina Verde	52	52M			

Consult Factory for additional paint charges and availability.

Project: _____

Fixture Type: _____ Quantity: _____

Customer: _____



FINISHES COLORS

STANDARD



PREMIUM

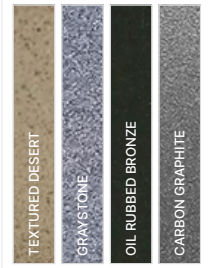

FINISHES

- A polyester powder coat high quality finish is electro-statically applied and baked at 430°F for exceptional durability and color retention. Products undergo an intensive five-step cleansing and pretreatment process for maximum paint adhesion.
- Marine grade finish provides superior salt, humidity and UV protection. This coating withstands up to 3,000 hours of continuous salt spray, comes with a 5-year warranty and is available in either a textured or gloss surface.

WARRANTY

See www.ANPlighting.com for complete fixture warranty.

LED warranty information

- 5 year limited warranty*
- *Limited Warranty: A typical year is defined as 4,380 hours of operation.